

## Submittal Data Sheet

<b>Set Code</b>	22022310003025
Indoor unit code	2202201101662322022011016701
Outdoor unit code	22022316001646
<b>Set Model</b>	DSAG11B-09HRFN1-MX7W(GA)*4+DSAG11B-12HRFN1-MV0W(GA)*1
Indoor unit model	DSAG11B-09HRFN1-MX7W(GA)*4
Outdoor unit model	D5OG-48HRFN1-M
<b>Certified</b>	<b>AHRI</b>  <b>UL</b> 



### SYSTEM PERFORMANCE DATA

<b>Power supply</b>		
Normal Operational Voltage	(V, Ph, Hz)	208/230V,1Ph, 60Hz
Voltage Range	(V)	187-253
<b>Electrical</b>		
Minimum circuit ampacity	(A)	40.0
Max.fuse	(A)	60.0
Connection wiring		14AWG*4 Stranded, unshielded
<b>Cooling</b>		
Capacity	(Btu/h)	48000(11600~49700)
Power Input	(W)	4440(810~4730)
Current	(A)	19.97(3.9~20.7)
SEER2	(Btu/W)	21.1
EER2	(Btu/W)	11.0
<b>Heating</b>		
Capacity	(Btu/h)	48000(33000~52900)
Power Input	(W)	4390(2860~4750)
Current	(A)	19.97(12.7~20.8)
HSPF2-4	(Btu/W)	9.5
HSPF2-5	(Btu/W)	7.2
COP	W/W	3.20
Heat at 17F(H32)	(Btu/h)	36000
Heat at 5F(H42)	(Btu/h)	33000
COP at 5F(H42)	W/W	1.80

### REFRIGERANT PIPE DATA

Design pressure	(PSIG)	550/340
Refrigerant Type		R410A
Refrigerant charge	oz	162.0
Refrigerant precharge	(ft)	25x5
Additional charge for each ft (Φ 6.35 (1/4") liquid pipe)	(oz/ft)	0.16
Additional charge for each ft (Φ 9.52 (3/8") liquid pipe)	(oz/ft)	0.32
Liquid side	(inch)	5x1/4"
	(mm)	5x6.35
Gas side	(inch)	3x3/8"+2x1/2"
	(mm)	3x9.52+2x12.7
Max. length for all rooms	(ft)	262.5
	(m)	80.0
Max. length for one indoor unit	(ft)	114.8
	(m)	35.0
Max. height difference between indoor and outdoor unit	(ft)	49.2
	(m)	15.0
Max. height difference between indoor units	(ft)	33.0
	(m)	10.0

Outdoor(cooling)	(Deg. °F)	5~122
	(Deg. °C)	-15 ~ 50
Outdoor(heating)	(Deg. °F)	-13 ~ 75
	(Deg. °C)	-25 ~ 24

### OUTDOOR UNIT DATA

<b>Compressor</b>		
Type		ROTARY
Model		ATQ360D1UMU
Brand		GMCC
Capacity	(Btu/h)	38214
Input	(W)	3040
Rated current (RLA)	(A)	24
Refrigerant oil/oil charge	(ml)	VG74/1400
<b>Outdoor fan motor</b>		
Model		ZKFN-85-8-22-5
Qty		2
Input	(W)	126.00
Output	(W)	85.00
RLA	(A)	2.50
Speed	(r/min)	900/850/800/750
<b>Air flow &amp; Noise level</b>		
Outdoor air flow (Max.)	(CFM)	4500.00
Outdoor noise level	[dB(A)]	62.00
<b>Outdoor unit</b>		
Dimension (W×D×H)	(inch)	37.48x16.34x52.48
	(mm)	952x415x1333
Packing (W×D×H)	(inch)	43.11x19.49x58.27
	(mm)	1095x495x1480
Net/ Gross weight	(lbs.)	225.53/256.62
	(kg)	102.3/116.4

Outdoor unit dimension

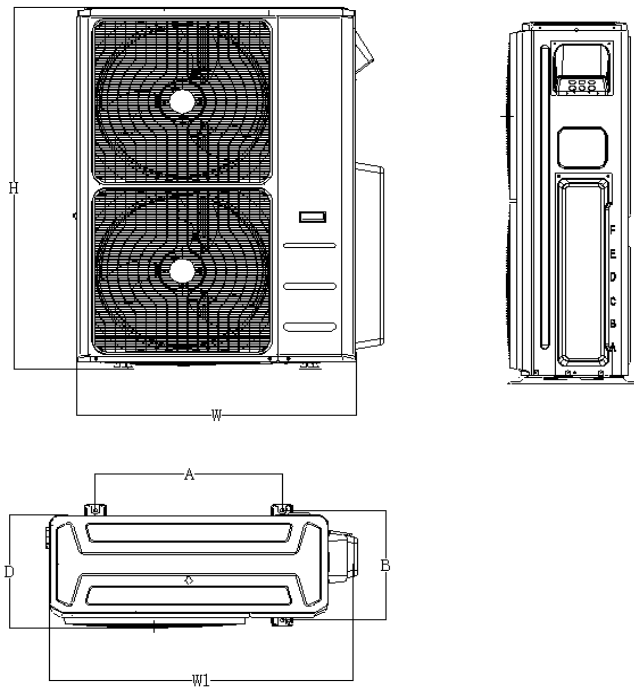

Unit	W	D	H	W1	A	B
mm	952	415	1333	1060	634	404
inch	37.5	16.3	52.5	41.7	25.0	15.9