



Submittal Data Sheet

Set Code	22022310003466
Indoor unit code	2202201101662322022011016701
Outdoor unit code	22022316001765
Set Model	DSAG11B-09HRFN1-MX7W(GA)*2+MSAG11B-12HRFN1-MV0W(GA)*3
Indoor unit model	DSAG11B-09HRFN1-MX7W(GA)*2
Outdoor unit model	D5OA-55HFN1-M
Certified	AHRI 
	UL 



SYSTEM PERFORMANCE DATA

Power supply		
Normal Operational Voltage	(V, Ph, Hz)	208/230V, 1Ph, 60Hz
Voltage Range	(V)	187-253
Electrical		
Minimum circuit ampacity	(A)	40.0
Max.fuse	(A)	60.0
Connection wiring		14AWG*4 Stranded, unshielded
Cooling		
Capacity	(Btu/h)	55000(11600-56900)
Power Input	(W)	5238(810-5800)
Current	(A)	23.5(3.9-26)
SEER2	(Btu/W)	20.2
EER2	(Btu/W)	10.5
Heating		
Capacity	(Btu/h)	55000(33000-63000)
Power Input	(W)	5117(2860-5650)
Current	(A)	22.5(12.7-25.5)
HSPF2-4	(Btu/W)	9.6
HSPF2-5	(Btu/W)	7.0
COP	W/W	3.15
Heat at 17F(H32)	(Btu/h)	36400
Heat at 5F(H42)	(Btu/h)	33200
COP at 5F(H42)	W/W	1.80

REFRIGERANT PIPE DATA

Design pressure	(PSIG)	550/340
Refrigerant Type		R410A
Refrigerant charge	oz	162.0
Refrigerant precharge	(ft)	25x5
Additional charge for each ft (Φ 6.35 (1/4") liquid pipe)	(oz/ft)	0.16
Additional charge for each ft (Φ 9.52 (3/8") liquid pipe)	(oz/ft)	0.32
Liquid side	(inch)	5x1/4"
	(mm)	5x6.35
Gas side	(inch)	3x3/8"+2x1/2"
	(mm)	3x9.52+2x12.7
Max. length for all rooms	(ft)	262.5
	(m)	80.0
Max. length for one indoor unit	(ft)	114.8
	(m)	35.0
Max. height difference between indoor and outdoor unit	(ft)	49.2
	(m)	15.0
Max. height difference between indoor units	(ft)	33.0
	(m)	10.0

Outdoor(cooling)	(Deg. °F)	5~122
	(Deg. °C)	-15 ~ 50
Outdoor(heating)	(Deg. °F)	-13 ~ 75
	(Deg. °C)	-25 ~ 24

OUTDOOR UNIT DATA

Compressor		
Type		ROTARY
Model		KTQ420D1UMU
Brand		GMCC
Capacity	(Btu/h)	46744
Input	(W)	3700
Rated current (RLA)	(A)	25.0
Refrigerant oil/oil charge	(ml)	VG74/1400
Outdoor fan motor		
Model		ZKFN-85-8-22-5
Qty		2
Input	(W)	126.0
Output	(W)	85.0
RLA	(A)	2.5
Speed	(r/min)	900/850/800/750
Air flow & Noise level		
Outdoor air flow (Max.)	(CFM)	4500.00
Outdoor noise level	[dB(A)]	62.00
Outdoor unit		
Dimension (W×D×H)	(inch)	37.48x16.34x52.48
	(mm)	952x415x1333
Packing (W×D×H)	(inch)	43.11x19.49x58.27
	(mm)	1095x495x1480
Net/ Gross weight	(lbs.)	224.21/257.28
	(kg)	101.71/116.7

Outdoor unit dimension

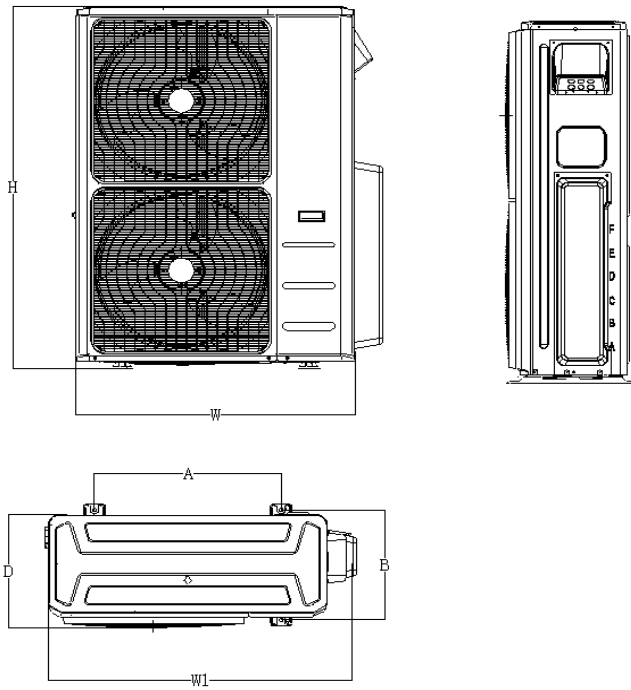

Unit	W	D	H	W1	A	B
mm	952	415	1333	1060	634	404
inch	37.5	16.3	52.5	41.7	25.0	15.9