



Submittal Data Sheet

Set Code	22022010015717
Indoor unit code	22022011016981
Outdoor unit code	22022016016740
Set Model	
Indoor unit model	DSAG11B-12HRFN1-BS0W
Outdoor unit model	DOX230-12HFN1-BS8W
Certified	
AHRI	
UL	



SYSTEM PERFORMANCE DATA

Power supply		
Normal Operational Voltage	(V, Ph, Hz)	115, 1, 60
Voltage Range	(V)	103.5-126.5
Electrical		
Minimum circuit ampacity	(A)	18.5
Max.fuse	(A)	25
Connection wiring		14*4 AWG
Cooling		
Rated Capacity	(Btu/h)	12000
Capacity Range	(Btu/h)	3800~12100
Power Input (Max)	(W)	1165
Rated current	(A)	10.13
SEER	(Btu/W)	20
EER	(Btu/W)	10.3
Heating at 47F		
Rated Capacity	(Btu/h)	12000
Capacity Range	(Btu/h)	2730~12500
Power Input (Max)	(W)	1154
Rated current	(A)	10.05
HSPF4	(Btu/W)	10.8
HSPF5	(Btu/W)	8.5
COP	W/W	3.05
Heating at 17F		
Max Capacity	(Btu/h)	9000

REFRIGERANT PIPE DATA

Design pressure	(PSIG)	550/340
Refrigerant Type	(Oz)	R410A/28.6
Refrigerant precharge	(ft)	25.0
	(m)	7.6
Additional charge for each ft	(oz/ft)	0.16
	(g/ft)	15
Liquid side/ Gas side	(inch)	1/4" / 1/2"
	(mm)	φ6.35 / φ12.7
Max. pipe length	(ft)	82.0
	(m)	25.0
Max. difference in level	(ft)	32.8
	(m)	10.0
Connection method		(Flared)
Indoor(cooling/ heating)	(Deg. °F)	60 ~ 90 / 32 ~ 86
	(Deg. °C)	16 ~ 32 / 0 ~ 30
Outdoor(cooling/heating)	(Deg. °F)	5~122 / 5~75
	(Deg. °C)	-15 ~ 50 / -15 ~ 24
Application area	(sq.ft)	172.22 ~ 247.57
	(m2)	16 ~ 23

INDOOR UNIT DATA

Indoor fan motor		
Type		Cross-Flow
Model		ZKFP-20-8-113
Qty		1
Input	(W)	35.0
RLA	(A)	-
LRA	(A)	---
Winding Resistance	(Ω)	---
Capacitor	(uF)	---
Speed(Hi/Mi/Lo)	(r/min)	850/750/450
Air flow & Noise level		
Indoor air flow (Hi/Med/Lo) (No duct)	(CFM)	300.00/241.18/176.47
Indoor noise level (Hi/Med/Lo)	[dB(A)]	41/35/26.5
Dehumidification		
	(Pint/H)	---
Indoor unit		
Dimension (WxDxH)	(inch)	31.57x7.87x11.61
	(mm)	802x200x295
Packing(WxDxH)	(inch)	34.45x11.22x14.96
	(mm)	875x285x380
Net/Gross weight	(lbs.)	18.52/24.03
	(kg)	8.4/10.9

OUTDOOR UNIT DATA

Compressor		
Type		KSN98D64UFZ3
Model		ROTARY
Brand		GMCC
Capacity	(Btu/h)	6585 / 10578
Input	(W)	292 / 765
Rated current (RLA)	(A)	-
Refrigerant oil/oil charge	(ml)	-
Throttle		Capillary
Outdoor fan motor		
Model		ZKFN-34-10-1-3
Qty		1
Input	(W)	--
RLA	(A)	--
Speed	(r/min)	780/700/600
Air flow & Noise level		
Outdoor air flow (Max.)	(CFM)	1235.29
Outdoor noise level	[dB(A)]	53.50
Outdoor unit		
Dimension (WxDxH)	(inch)	30.12x11.93x21.85
	(mm)	765x303x555
Packing (WxDxH)	(inch)	34.92x13.27x24.02
	(mm)	887x337x610
Net/ Gross weight	(lbs.)	62.17/67.68
	(kg)	28.2/30.7

Indoor unit dimension

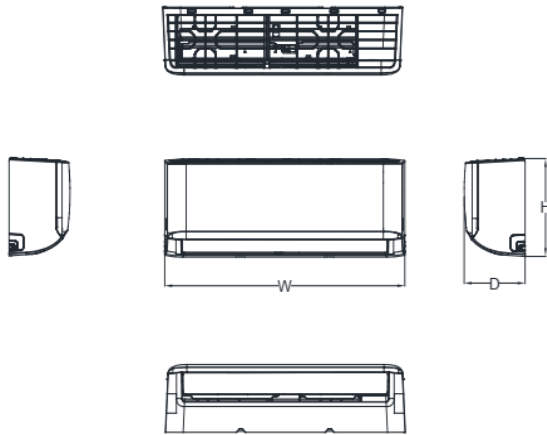

Capacity	Body Code	W(mm/inch)	D(mm/inch)	H(mm/inch)
6K-11K	A	729/28.7	200/7.87	292/11.5
8K-14K	B	802/31.57	200/7.87	295/11.61
12K-21K	C	971/38.23	228/8.98	321/12.64
18K-28K	D	1082/42.6	234/9.21	337/13.27
27K-36K	F	1259/49.57	283/11.14	362/14.25

Outdoor unit dimension

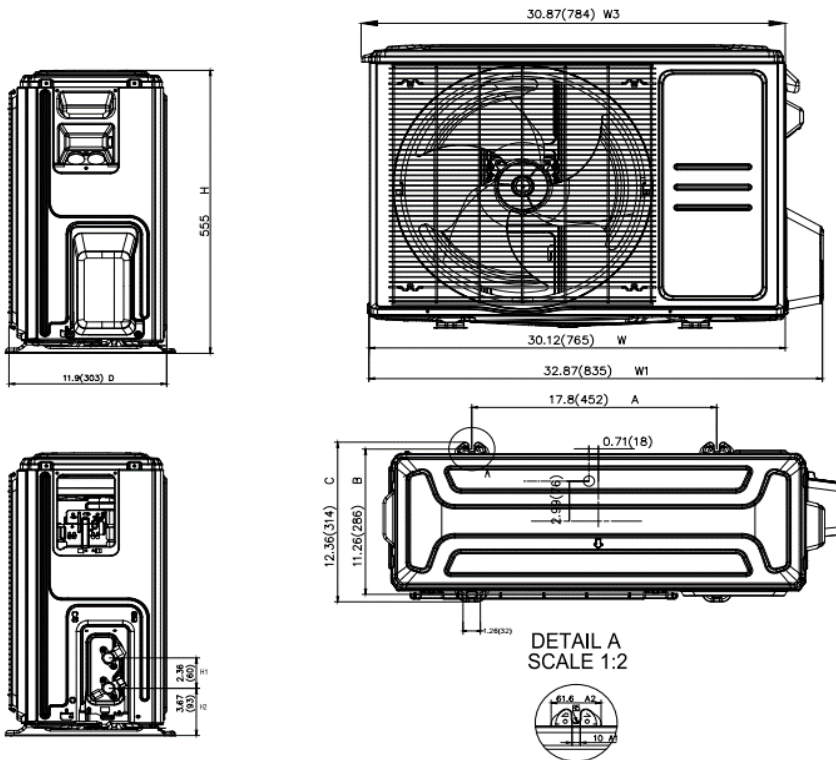

General Features

- Wireless Remote with LCD Display
- 46F Heating
- Sleep Mode
- Silent Mode
- Self Clean
- Follow Me (optional)

Extended Performance Data