



**Submittal Data Sheet
48K Regular**



Code	
Indoor unit code	22022511001716
Outdoor unit code	22022516000702
Model	
Indoor unit model	MCD-48HRFN1-M(D)
Outdoor unit model	MOE30U-48HFN1-M

PERFORMANCE DATA

Power supply	Ph-V-Hz	208/230V,1Ph,60Hz
--------------	---------	-------------------

Cooling

Capacity	Btu/h	48000
Input	W	5053
Rated current	A	23.1
EER	Btu/w	9.5
SEER	Btu/w	16.8

Heating at 47

Capacity	Btu/h	50000
Input	W	4727
Rated current	A	21.6
COP	W/W	3.10
HSPF4		11
HSPF5		9.4

Electrical

MINIMUM CIRCUIT AMPACITY	A	35
MAX. FUSE	A	50
Connection wiring		16*4 AWG

Compressor

Model		ATQ420D1UMU
Type		ROTARY
Brand		GMCC
Capacity	Btu/h	44697
Input	W	3420
Rated current(RLA)	A	23.5
Locked rotor Amp(LRA)	A	---
Thermal protector		---
Thermal protector position		---
Refrigerant oil/oil charge	ml	Ester Oil VG74/1400

SYSTEM DATA

Design pressure	PSIG	550/340 PSIG
Refrigerant type	oz	R410A/148.2
Refrigerant precharge	ft	25
Additional charge per ft.	oz	0.32
Liquid side/ Gas side	mm(in)	Φ9.52/Φ15.9(3/8"/5/8")
Max. refrigerant pipe length	ft	213
Max. difference in level	ft.	98

INDOOR UNIT DATA

Indoor fan motor

Model		ZKFN-170-8-1
Type		DC
Input		232
RLA	A	1.6
LRA	A	---
Winding Resistance	Ω	---
Capacitor	uF	---
Speed(Hi/Mi/Lo)	r/min	900/800/700

Air flow & Noise level

Indoor air flow (Hi/Lo)	CFM	1177/1030/853
Indoor noise level (Hi/Lo)	dB(A)	55/52/49

Indoor unit

Dimension(W*D*H)	inch	33.07x33.07x11.3
Packing (W*D*H)	inch	35.43x35.43x11.5
Net/Gross weight	lbs.	63.27/72.53

OUTDOOR UNIT DATA

Outdoor fan motor

Model		ZKFN-85-8-22+ZKFN-85-8-22-2
Type		DC
Input		126
RLA	A	0.39
LRA	A	---
Winding Resistance	Ω	---
Capacitor	uF	---
Speed	r/min	900

Air flow & Noise level

Outdoor air flow	CFM	4470
Outdoor noise level	dB(A)	62.5

Outdoor unit

Dimension(W*D*H)	inch	37.48x16.34x52.48
Packing (W*D*H)	inch	43.11x19.49x58.27
Net/Gross weight	lbs.	217.4/246.0

Operation temperature

Indoor(cooling/ heating)	Deg. F	62~90/32~86
Outdoor(cooling/heating)	Deg. F	5~122/ 5~86
Application area	sq.ft	700-1009

INDOOR UNIT

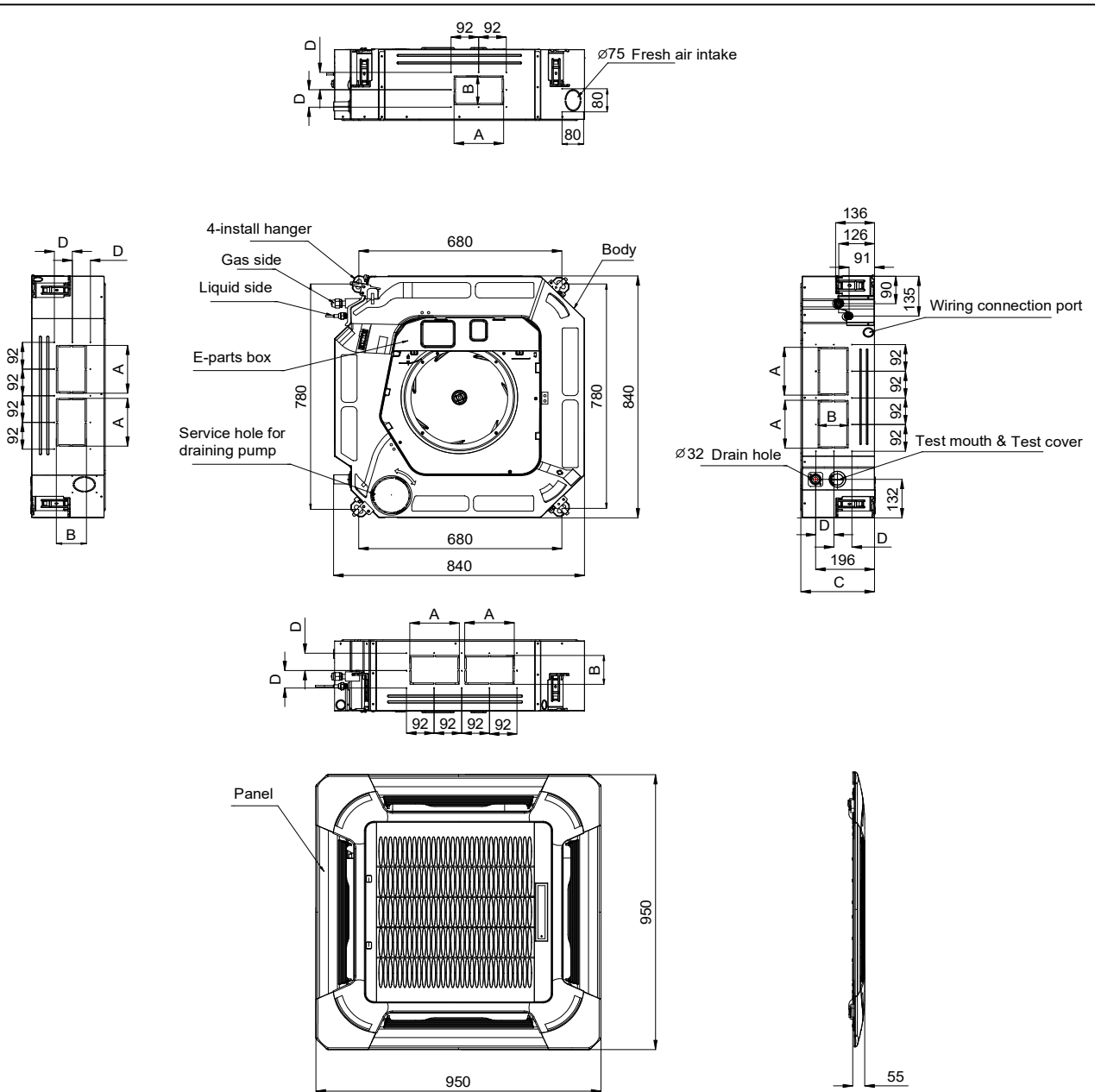

Capacity (Btu/h)		A	B	C	D
48K	mm	160	95	287	60
	inch	6.30	3.74	11.30	2.36

OUTDOOR UNIT

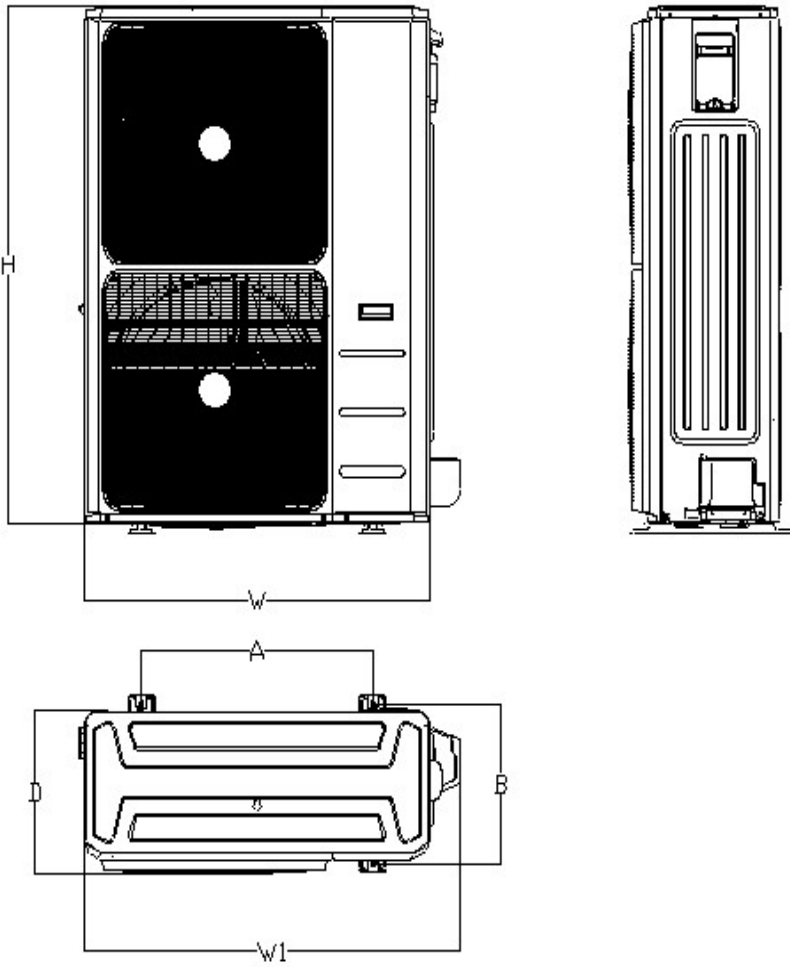

4

Model	W (inch)	D (inch)	H (inch)	W1 (inch)	A (inch)	B (inch)
MOE30U-48HFN1-M	37.5	16.3	52.5	41.1	25.0	15.9