

Submittal Data Sheet 36K Regular

Code	
Indoor unit code	22022511000666
Outdoor unit code	22022516000402
Model	
Indoor unit model	MCD-36HRFN1-M(C)
Outdoor unit model	MOD30U-36HFN1-M



PERFORMANCE DATA

Power supply	Ph-V-Hz	208/230V,1Ph,60Hz
--------------	---------	-------------------

Cooling

Capacity	Btu/h	36000
Input	W	4000
Rated current	A	16.7
EER	Btu/w	9
SEER	Btu/w	17.5

Heating at 47

Capacity	Btu/h	38000
Input	W	3700
Rated current	A	16.93
COP	W/W	3.01
HSPF4		10.5
HSPF5		9.1

Electrical

MINIMUM CIRCUIT AMPACITY	A	30
MAX. FUSE	A	50
Connection wiring		16*4 AWG

Compressor

Model		ATF310D43UMT
Type		ROTARY
Brand		GMCC
Capacity	Btu/h	32380
Input	W	2600
Rated current(RLA)	A	22
Locked rotor Amp(LRA)	A	---
Thermal protector		---
Thermal protector position		---
Refrigerant oil/oil charge	ml	POE (VG74)/1000

SYSTEM DATA

Design pressure	PSIG	550/340 PSIG
Refrigerant type	oz	R410A/107.6
Refrigerant precharge	ft	25
Additional charge per ft.	oz	0.32
Liquid side/ Gas side	mm(in)	Φ9.52/Φ15.9(3/8"/5/8")
Max. refrigerant pipe length	ft	213
Max. difference in level	ft.	98

INDOOR UNIT DATA

Indoor fan motor

Model		ZKFP-124-8-2
Type		DC
Input		141
RLA	A	1.5
LRA	A	---
Winding Resistance	Ω	---
Capacitor	uF	---
Speed(Hi/Mi/Lo)	r/min	720/630/560

Air flow & Noise level

Indoor air flow (Hi/Lo)	CFM	1095/958/809
Indoor noise level (Hi/Lo)	dB(A)	55/52/49

Indoor unit

Dimension(W*D*H)	inch	33.07x33.07x9.65
Packing (W*D*H)	inch	35.43x35.43x10.12
Net/Gross weight	lbs.	58.2/66.14

OUTDOOR UNIT DATA

Outdoor fan motor

Model		ZKFN-120-8-2
Type		DC
Input		150
RLA	A	1
LRA	A	---
Winding Resistance	Ω	---
Capacitor	uF	---
Speed	r/min	950

Air flow & Noise level

Outdoor air flow	CFM	2530
Outdoor noise level	dB(A)	66

Outdoor unit

Dimension(W*D*H)	inch	37.24x16.14x31.89
Packing (W*D*H)	inch	42.91x19.69x34.45
Net/Gross weight	lbs.	148.59/160.94

Operation temperature

Indoor(cooling/ heating)	Deg. F	62~90/32~86
Outdoor(cooling/heating)	Deg. F	5~122/ 5~86
Application area	sq.ft	517-757

INDOOR UNIT

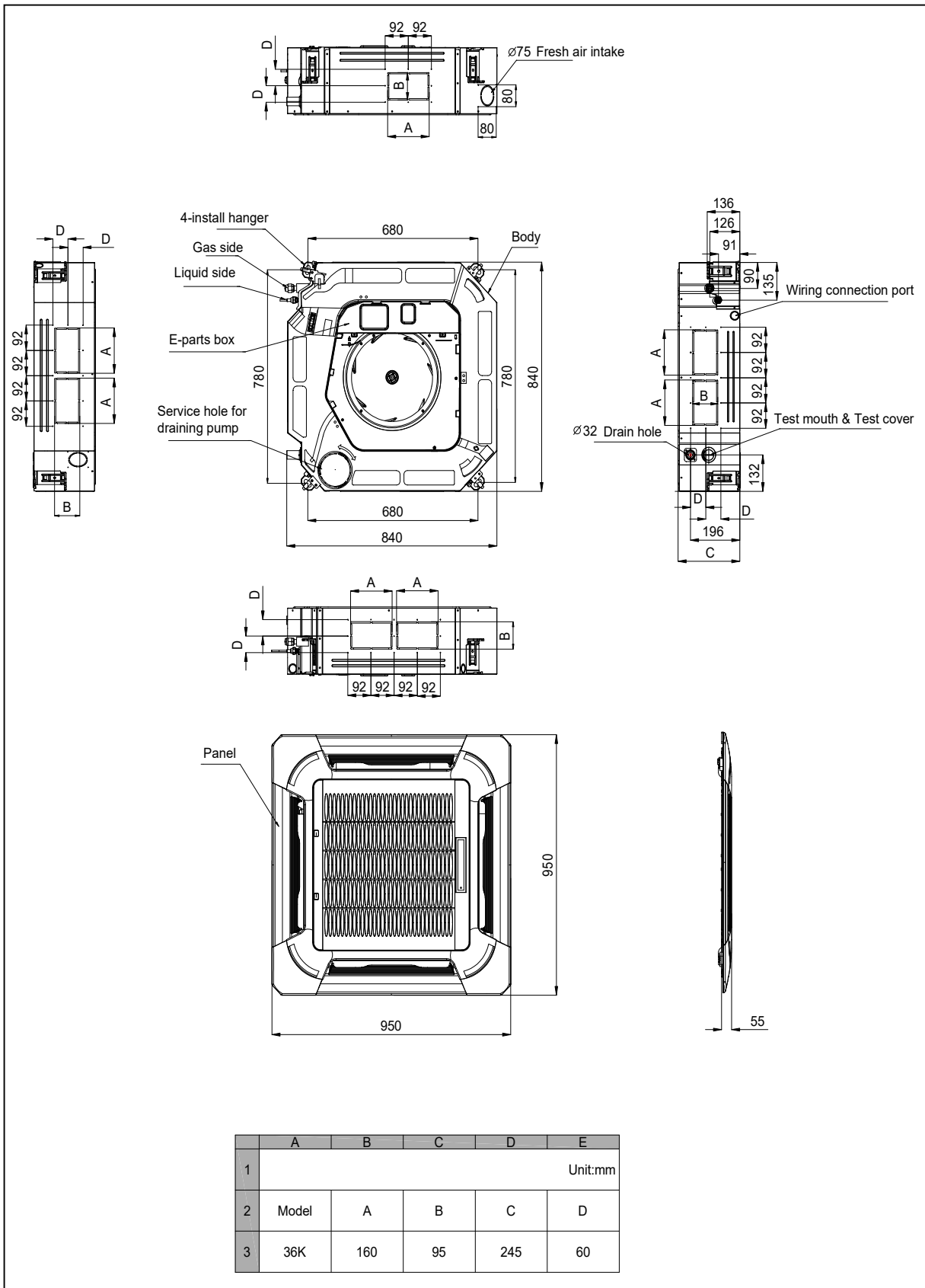

	A	B	C	D	E
1	Unit:mm				
2	Model	A	B	C	D
3	36K	160	95	245	60

OUTDOOR UNIT

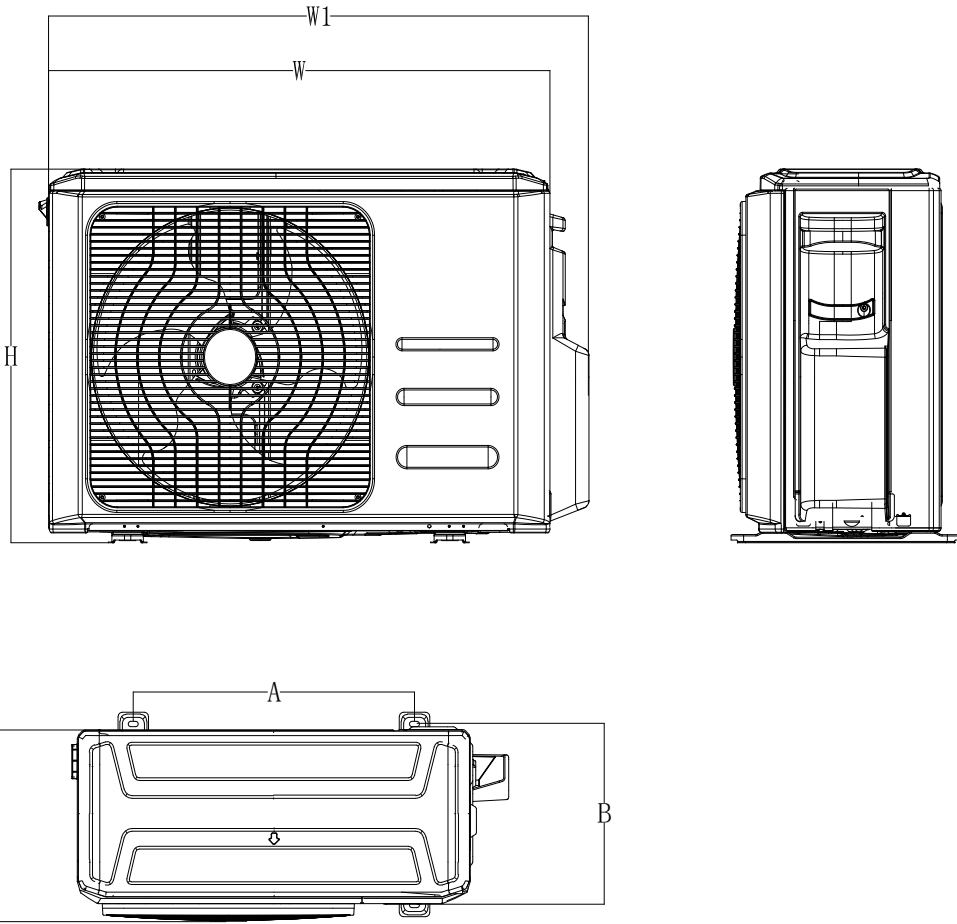

Model	W (inch)	D (inch)	H (inch)	W1 (inch)	A (inch)	B (inch)
MOD30U-36HFN1-M	37.2	16.1	31.9	40.6	26.5	15.9