

Submittal Data Sheet
18K Energy Star

Code	
Indoor unit code	22022511000711
Outdoor unit code	22022016005162
Model	
Indoor unit model	CCA3U-18HRFN1-M(C)
Outdoor unit model	MOCA31-18HFN1-MT0W



PERFORMANCE DATA

Power supply	Ph-V-Hz	208-230V,1Ph,60Hz
Cooling		
Capacity	Btu/h	18000
Input	W	1440
Rated current	A	6.59
EER	Btu/w	12.5
SEER	Btu/w	20
Heating at 47		
Capacity	Btu/h	18000
Input	W	1636
Rated current	A	7.49
COP	W/W	3.22
HSPF4		10.3
HSPF5		8.8
Electrical		
MINIMUM CIRCUIT AMPACITY	A	15
MAX. FUSE	A	20
Connection wiring		16*4 AWG
Compressor		
Model		ASM135D23UFZ
Type		ROTARY
Brand		GMCC
Capacity	Btu/h	13836
Input	W	1035
Rated current(RLA)	A	10.5
Locked rotor Amp(LRA)	A	---
Thermal protector		---
Thermal protector position		---
Refrigerant oil/oil charge	ml	ESTER OIL VG74/450
SYSTEM DATA		
Design pressure	PSIG	550/340 PSIG
Refrigerant type	oz	R410A/68.8
Refrigerant precharge	ft	25
Additional charge per ft.	oz	0.16
Liquid side/ Gas side	mm(in)	Φ6.35/Φ12.7(1/4"/1/2")
Max. refrigerant pipe length	ft	98
Max. difference in level	ft.	0

INDOOR UNIT DATA

Indoor fan motor		
Model		ZKFP-46-8-1
Type		DC
Input		45
RLA	A	0.465
LRA	A	---
Winding Resistance	Ω	---
Capacitor	uF	---
Speed(Hi/Mi/Lo)	r/min	730/630/570
Air flow & Noise level		
Indoor air flow (Hi/Lo)	CFM	560483/415
Indoor noise level (Hi/Lo)	dB(A)	44/39/36
Indoor unit		
Dimension(W*D*H)	inch	22.44x22.44x10.24
Packing (W*D*H)	inch	25.79x25.79x11.42
Net/Gross weight	lbs.	35.49/41.23

OUTDOOR UNIT DATA

Outdoor fan motor		
Model		ZKFN-50-8-2
Type		DC
Input		115
RLA	A	0.60
LRA	A	---
Winding Resistance	Ω	---
Capacitor	uF	---
Speed	r/min	850
Air flow & Noise level		
Outdoor air flow	CFM	1470
Outdoor noise level	dB(A)	60
Outdoor unit		
Dimension(W*D*H)	inch	33.27x14.29x27.64
Packing (W*D*H)	inch	37.99x15.55x29.72
Net/Gross weight	lbs.	106.9/112.5
Operation temperature		
Indoor(cooling/ heating)	Deg. F	62~90/32~86
Outdoor(cooling/heating)	Deg. F	-13~122/ -13~86
Application area	sq.ft	258-376

INDOOR UNIT

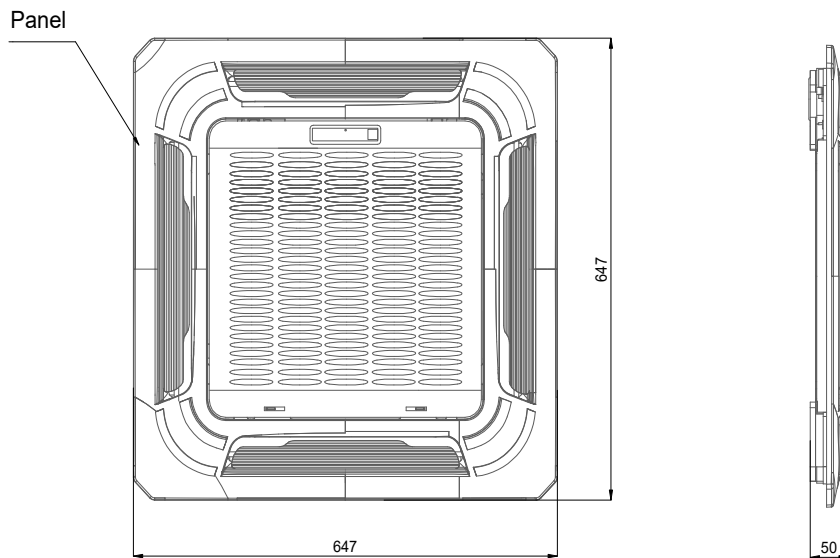
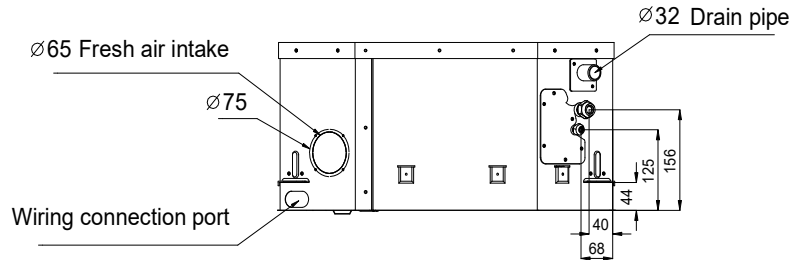
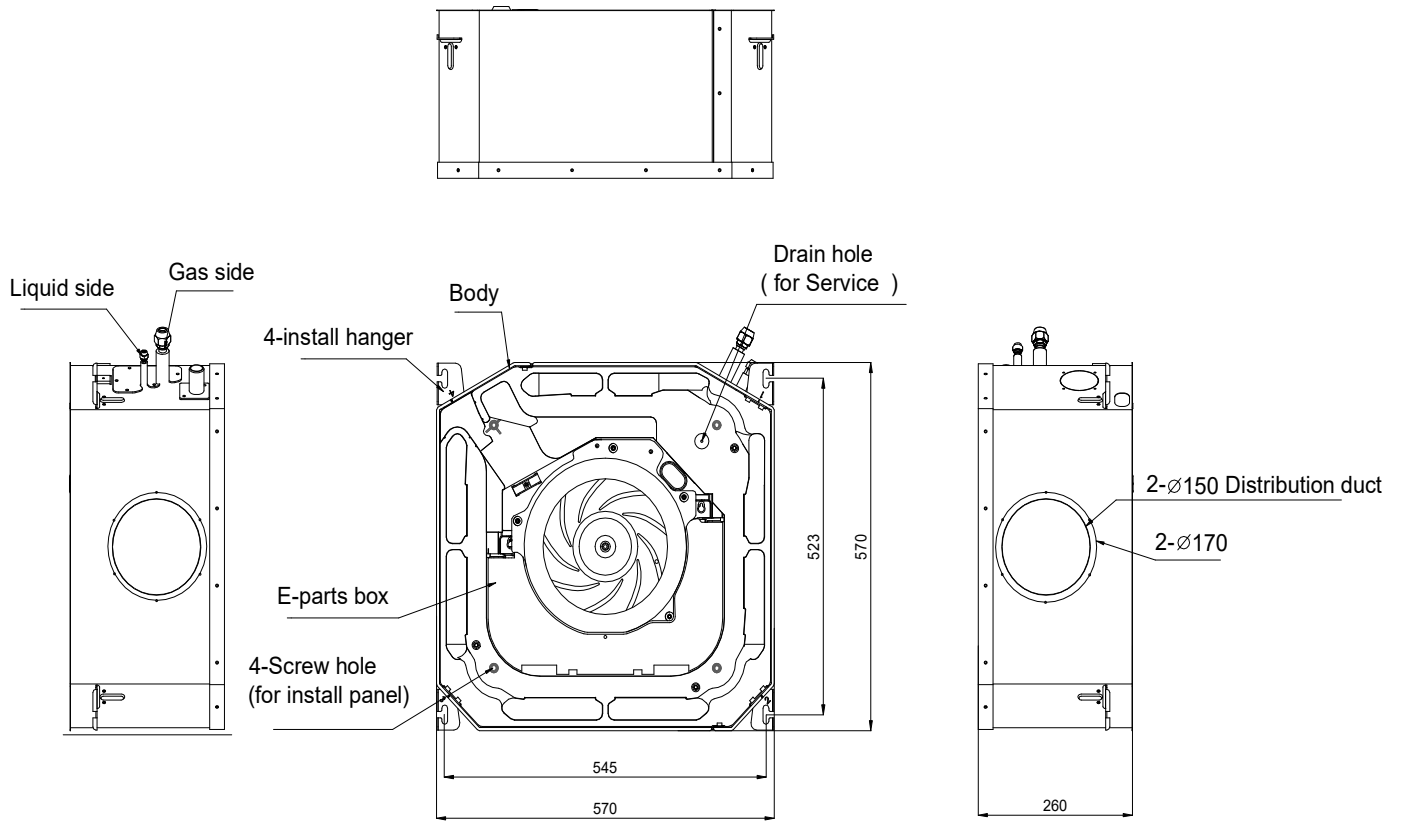

OUTDOOR UNIT

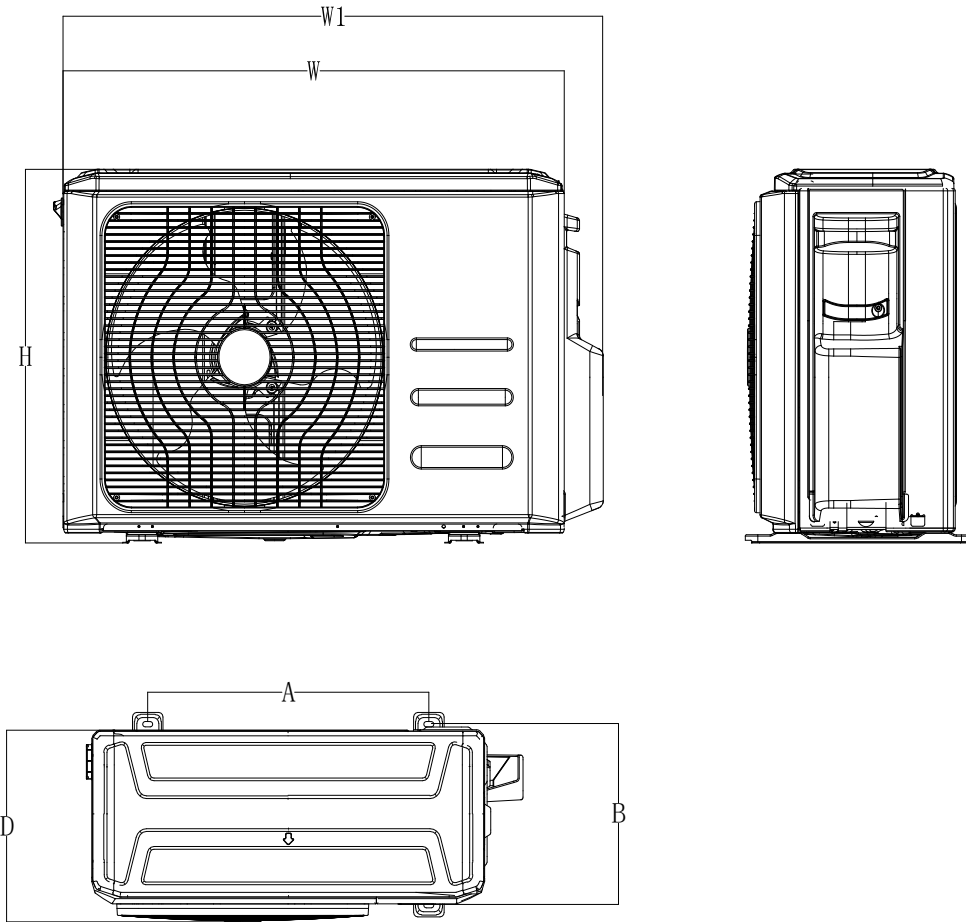

Model	W (inch)	D (inch)	H (inch)	W1 (inch)	A (inch)	B (inch)
MOCA31-18HFN1-MTOW	33.3	14.3	27.6	36.0	21.3	13.8