

Submittal Data Sheet
12K Energy Star

Code	
Indoor unit code	22022511000710
Outdoor unit code	22022016005161
Model	
Indoor unit model	CCA3U-12HRFN1-M(C)
Outdoor unit model	MOB30-12HFN1-MTOW



PERFORMANCE DATA

Power supply	Ph-V-Hz	208-230V,1Ph,60Hz
Cooling		
Capacity	Btu/h	12000
Input	W	858
Rated current	A	3.9
EER	Btu/w	14
SEER	Btu/w	21.5
Heating at 47		
Capacity	Btu/h	12000
Input	W	951
Rated current	A	4.2
COP	W/W	3.7
HSPF4		10.5
HSPF5		8.4
Electrical		
MINIMUM CIRCUIT AMPACITY	A	12
MAX. FUSE	A	15
Connection wiring		16*4 AWG
Compressor		
Model		ASM98D32UFZ
Type		ROTARY
Brand		GMCC
Capacity	Btu/h	11157
Input	W	800
Rated current(RLA)	A	6.8
Locked rotor Amp(LRA)	A	---
Thermal protector		---
Thermal protector position		---
Refrigerant oil/oil charge	ml	ESTER OIL VG74/370
SYSTEM DATA		
Design pressure	PSIG	550/340 PSIG
Refrigerant type	oz	R410A/40.6
Refrigerant precharge	ft	25
Additional charge per ft.	oz	0.16
Liquid side/ Gas side	mm(in)	Φ6.35/Φ12.7(1/4"/1/2")
Max. refrigerant pipe length	ft	82
Max. difference in level	ft.	33

INDOOR UNIT DATA

Indoor fan motor		
Model		ZKFP-46-8-1
Type		DC
Input		45
RLA	A	0.465
LRA	A	---
Winding Resistance	Ω	---
Capacitor	uF	---
Speed(Hi/Mi/Lo)	r/min	680/580/500
Air flow & Noise level		
Indoor air flow (Hi/Lo)	CFM	379/309/261
Indoor noise level (Hi/Lo)	dB(A)	43/39/36
Indoor unit		
Dimension(W*D*H)	inch	22.44x22.44x10.24
Packing (W*D*H)	inch	25.79x25.79x11.42
Net/Gross weight	lbs.	35.27/41

OUTDOOR UNIT DATA

Outdoor fan motor		
Model		ZKFN-40-8-1L
Type		DC
Input		63
RLA	A	0.4
LRA	A	---
Winding Resistance	Ω	---
Capacitor	uF	---
Speed	r/min	800
Air flow & Noise level		
Outdoor air flow	CFM	1177
Outdoor noise level	dB(A)	55
Outdoor unit		
Dimension(W*D*H)	inch	31.5x13.11x21.81
Packing (W*D*H)	inch	36.22x15.35x24.21
Net/Gross weight	lbs.	76.72/82.67
Operation temperature		
Indoor(cooling/ heating)	Deg. F	62~90/32~86
Outdoor(cooling/heating)	Deg. F	-13~122/ -13~86
Application area	sq.ft	172-252

INDOOR UNIT

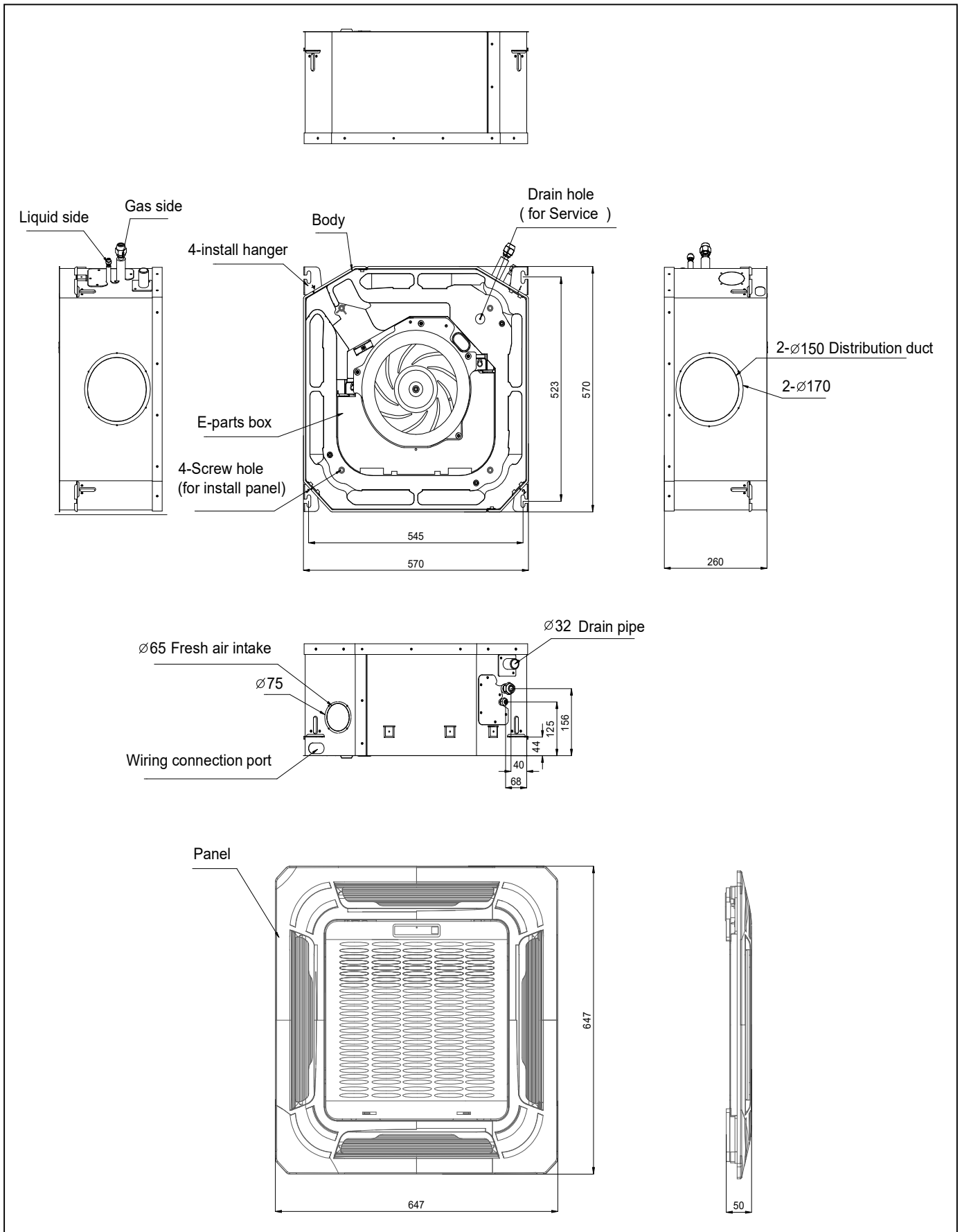

OUTDOOR UNIT

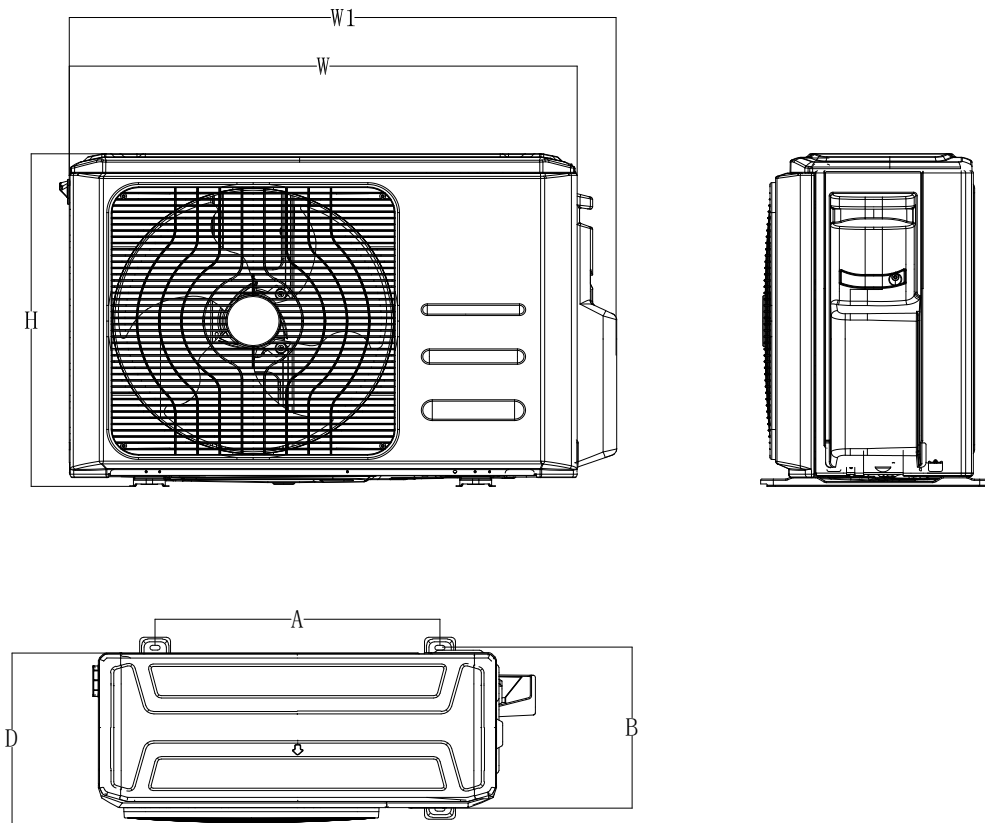

Model	W (inch)	D (inch)	H (inch)	W1 (inch)	A (inch)	B (inch)
MOB30-12HFN1-MTOW	31.50	13.11	21.81	34.3	20.2	13.4